

stormcalcs

USE Trail Dr

Adam; Please check storm drainage system. zoning is fine. Brent

Storm Water Calculations

Project: PATTON AUTO LOT, TRAIL DRIVE, NAPOLEON, OHIO

Runoff flows & Coefficients, Pre & Post development

By:RDS Date: July 17, 1998

1) Existing (Pre-development) runoff:					
Area(Ac.)	Land use description	"C"	"I" in/hr	"Q" cfs	
0.676	Grassed area	0.30	2.60	0.527	
	Building roof			0.000	
	Asphalt pavement			0.000	
	Concrete pavement			0.000	
Total Existing Runoff				0.527	
2) Proposed (Post-development) runoff:					
Project Description:					
Calculations are based on an initial development with 22,800 s.f. of asphalt pavement to provide a surface for display of automobiles, and includes a small area of pavement to connect the new display area to the existing Patton sales and parking lot north of their building. Yard areas north of paved lot and concrete drive approach fall toward street.					
Lot 6, Beck & Schultz Addition					
Area(Ac.)	Land use description	"C"	"CA"		
0.000	Building roof	0.90	0.000		
0.523	Asphalt pavement	0.85	0.445		
0.000	Concrete pavement	0.90	0.000		
0.153	Lawn-grassed area	0.25	0.038		
0.676	TOTAL AREA	TOTAL	0.483		
Weighted "C" =		TOTAL "CA"	0.483		
		TOTAL "A"	0.676		
Weighted "C" =		0.714			
3) Proposed (Post-development) runoff:					
Area(Ac.)	Land use description	"C"	"I" in/hr	"Q" cfs	
0.676	See "2" Above	0.714	2.60	1.255	
Total Proposed Runoff				1.255	
4) Critical Storm Determination:					
(1.255-0.527)/(0.527)=1.38 or 138% therefore		Critical Storm = 25 Year			

Storm Water Calculations						
Project: PATTON AUTO LOT, TRAIL DRIVE, NAPOLEON, OHIO						
Storm Water Detention Calculations						
By:RDS	Date: July 17, 1998					
Site Area:	0.676					
Weighted "C"	0.714					
"T"(min.)	"I"(in/hr)	"CA"	"Q" in (cfs)	"Q" out (cfs)	"Q" in-"Q" out (cfs)	Detention Volume(c.f.)
Time of Concentration	25 Year Storm Intensity					
20	4.43	0.4828	2.14	0.527	1.61	1934
30	3.57	0.4828	1.72	0.527	1.20	2153
40	3.01	0.4828	1.45	0.527	0.93	2222
50	2.58	0.4828	1.25	0.527	0.72	2155
60	2.30	0.4828	1.11	0.527	0.58	2099
70	2.05	0.4828	0.99	0.527	0.46	1942
80	1.86	0.4828	0.90	0.527	0.37	1779
90	1.70	0.4828	0.82	0.527	0.29	1585
100	1.58	0.4828	0.76	0.527	0.24	1413
110	1.46	0.4828	0.70	0.527	0.18	1172
120	1.36	0.4828	0.66	0.527	0.13	931
130	1.28	0.4828	0.62	0.527	0.09	707
140	1.21	0.4828	0.58	0.527	0.06	478
150	1.14	0.4828	0.55	0.527	0.02	208
160	1.09	0.4828	0.53	0.527	0.00	-10
170	1.04	0.4828	0.50	0.527	-0.03	-257
180	1.00	0.4828	0.48	0.527	-0.04	-480
190	0.96	0.4828	0.46	0.527	-0.06	-727
200	0.92	0.4828	0.44	0.527	-0.08	-997
210	0.88	0.4828	0.42	0.527	-0.10	-1290
220	0.85	0.4828	0.41	0.527	-0.12	-1543
230	0.82	0.4828	0.40	0.527	-0.13	-1813
240	0.79	0.4828	0.38	0.527	-0.15	-2100
250	0.77	0.4828	0.37	0.527	-0.16	-2333
260	0.74	0.4828	0.36	0.527	-0.17	-2652
270	0.71	0.4828	0.34	0.527	-0.18	-2989
Minimum Detention Volume Required =					2222	Cubic Feet
Area required for 1' depth of storage =					0.051	Acres
Area required for 1.5' depth of storage =					0.034	Acres
Area required for 2' depth of storage =					0.026	Acres
Area required for 2.5' depth of storage =					0.020	Acres

Storm Water Calculations					
Project: PATTON AUTO LOT, TRAIL DRIVE, NAPOLEON, OHIO					
Drainage Area Flow Calculations					
R.D.S.		Date: July 17, 1998	Critical Storm "I" inches		3.01
			Time of Concentration "		40
Area 1	Description:				
	Proposed Auto display lot				
	Area(Ac.)	Land use description	"C"	"I" in/hr	"Q" cfs
	0.000	Building roof	0.9	3.01	0.000
	0.523	Asphalt pavement	0.85	3.01	1.338
	0.000	Concrete pavement	0.90	3.01	0.000
	0.153	Lawn-grassed area	0.25	3.01	0.115
	Total Flow ~ Area 1				1.453
Area 2	Description:				
	x				
	x				
	Area(Ac.)	Land use description	"C"	"I" in/hr	"Q" cfs
	0.000	Building roof	0.90	3.01	0.000
	0.000	Asphalt pavement	0.85	3.01	0.000
	0.000	Concrete pavement	0.90	3.01	0.000
	0.000	Lawn-grassed area	0.25	3.01	0.000
	Total Flow ~ Area 2				0.000
Area 3	Description:				
	x				
	x				
	Area(Ac.)	Land use description	"C"	"I" in/hr	"Q" cfs
	0.000	Building roof	0.90	3.01	0.000
	0.000	Asphalt pavement	0.85	3.01	0.000
	0.000	Concrete pavement	0.90	3.01	0.000
	0.000	Lawn-grassed area	0.25	3.01	0.000
	Total Flow ~ Area 3				0.000
Outlet size; flow requirement					
	Description:				
	Total site draining to City storm sewer				
	Area(Ac.)	Land use description	"C"	"I" in/hr	"Q" cfs
	0.676	Total site ~ Weighted "C"	0.714	3.01	1.453
	Total Flow =				1.453
	Maximum discharge allowable per City of Napoleon = Q2 = 0.527				
	USE 6" ADS N12 OUTLET PIPE @ 0.75% = 0.526 cfs.				

TABLE 4

CIRCULAR PIPE FLOW CAPACITY
Full Flow (cubic feet per second)

Mannings "n" = 0.012

Dia. *Conv. (in.)	% Slope (feet per 100 feet)																
	0.02	0.05	0.10	0.20	0.35	0.50	0.75	1.00	1.25	1.50	1.75	2.0	2.5	5.0	10.0	20.0	
3	0.957	0.014	0.021	0.030	0.043	0.057	0.068	0.083	0.096	0.107	0.12	0.13	0.14	0.15	0.21	0.30	0.43
4	2.062	0.029	0.046	0.065	0.092	0.122	0.146	0.179	0.206	0.231	0.25	0.27	0.29	0.33	0.46	0.65	0.92
5	3.738	0.053	0.084	0.118	0.167	0.221	0.264	0.324	0.374	0.418	0.46	0.49	0.53	0.59	0.84	1.18	1.67
6	5.079	0.086	0.136	0.192	0.272	0.360	0.430	0.526	0.608	0.680	0.74	0.80	0.86	0.96	1.36	1.92	2.72
8	13.091	0.185	0.293	0.414	0.585	0.774	0.926	1.134	1.309	1.464	1.60	1.73	1.85	2.07	2.93	4.14	5.85
10	23.74	0.34	0.53	0.75	1.06	1.40	1.68	2.06	2.37	2.65	2.91	3.14	3.36	3.75	5.31	7.51	10.61
12	38.60	0.55	0.86	1.22	1.73	2.28	2.73	3.34	3.86	4.32	4.73	5.11	5.46	6.10	8.63	12.21	17.26
15	69.98	0.99	1.56	2.21	3.13	4.14	4.95	6.06	7.00	7.82	8.57	9.26	9.90	11.06	15.65	22.13	31.30
18	113.80	1.61	2.54	3.60	5.09	6.73	8.05	9.86	11.38	12.72	13.94	15.05	16.09	17.99	25.46	35.99	50.89
21	171.65	2.43	3.84	5.43	7.68	10.16	12.14	14.87	17.17	19.19	21.02	22.71	24.28	27.14	38.38	54.28	76.77
24	245.08	3.47	5.48	7.75	10.96	14.50	17.33	21.22	24.51	27.40	30.02	32.42	34.66	38.75	54.80	77.50	109.60
27	335.51	4.74	7.50	10.61	15.00	19.85	23.72	29.06	33.55	37.51	41.09	44.38	47.45	53.05	75.0	106.1	150.0
30	444.35	6.28	9.94	14.05	19.87	26.29	31.42	38.48	44.44	49.68	54.42	58.78	62.84	70.26	99.4	140.5	198.7
36	722.57	10.22	16.16	22.85	32.31	42.75	51.09	62.58	72.26	80.79	88.50	95.59	102.19	114.25	161.6	228.5	323.1
42	1089.9	15.41	24.37	34.47	48.74	64.5	77.1	94.4	109.0	121.9	133.5	144.2	154.1	172.3	243.7	344.7	487.4
48	1556.1	22.01	34.80	49.21	69.59	92.1	110.0	134.8	155.6	174.0	190.6	205.9	220.1	246.0	348.0	492.1	695.9

* Conveyance Factor = (1.486 x R^{2/3} x A) / n

STANDARD HEAVY DUTY PARKING STOP

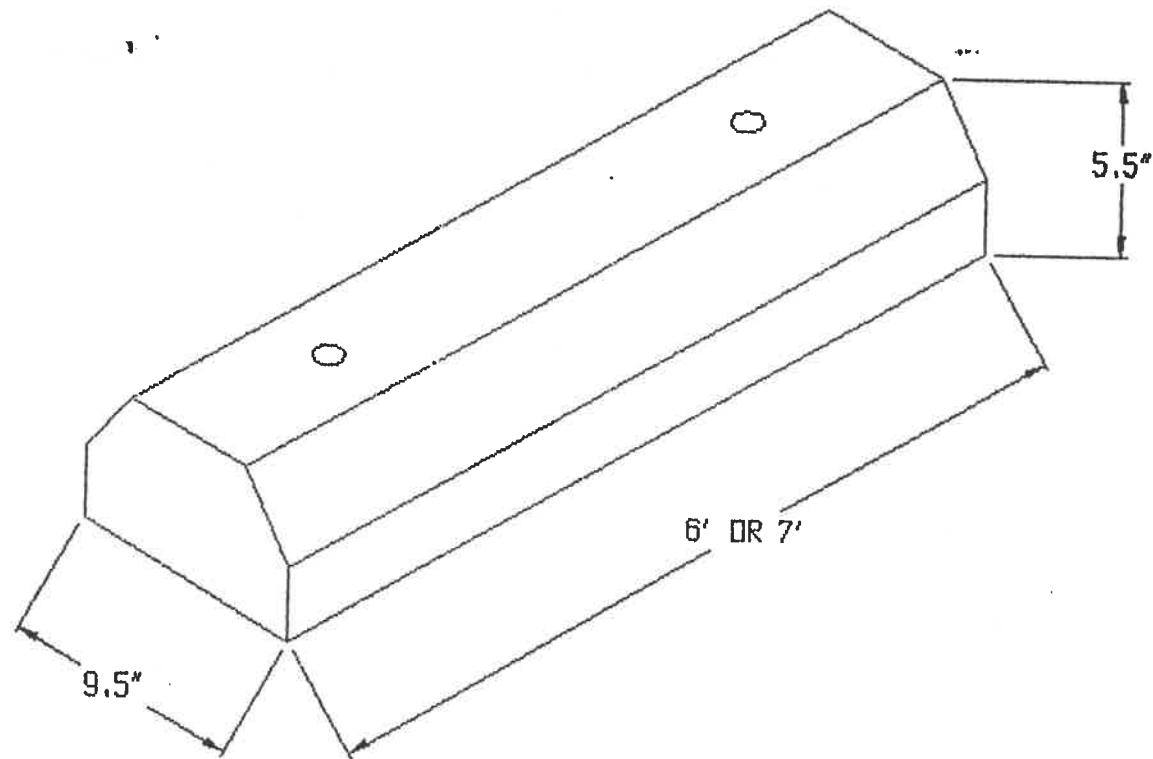

Wauseon Silo, Precast & Supply	
350 West Leggett Street P.O. Box 394 Wauseon, Ohio 43567	
CALL OR FAX FOR QUOTES	Phone: (419) 335-6041 Fax: (419) 335-1538 1-800-635-2946
QUALITY PRODUCTS & SERVICE SINCE 1932	

Fax Cover This is a confidential message, intended solely for the person to whom it is addressed. If you receive this message in error, please forward it to the correct person, or mail it back to us. Thank you.

To Ron Sonnenberg - New Dimensions
Fax No. (419) 599-8339
From Adam C. Hoff, P.E. - City Engineer *ACH*
Date 7/27/98
Subject Lot #6 Beck & Schultz Subdivision
Pages 1, including this one

The zoning for the referenced property is acceptable for the proposed auto sales lot. Based upon my review of the site plan submitted, please note the following comments:

1. If not already done, a \$25.00 plan review fee, along with three (3) copies of the site plan, are required.
2. The City standard for 2x2 catch basin castings are East Jordan 5110 with Type M3 grates, or equal.
3. Depending on whether the facility will be receiving vehicles by semi and the frequency of such deliveries, the owner may wish to increase the pavement section for the lot as well as the thickness of the concrete drive approach. If such deliveries are expected I would recommend a minimum of 4" of asphalt (2-1/2" - 402 w/ 1-1/2" - 404) over 10" of 304 and an 8" drive approach over 6" of 304.
4. The City will need to inspect the grading and the forms for the drive approach prior to pouring the concrete. We will also need to inspect any connections made to the storm sewer. No inspection fees will be charged.

If you have any questions, please call me at 592-4010.

c: Jeff Marihugh, Rex Moll, *Brent Daneman*

255 W. Riverview Ave.
Napoleon, Ohio 43545

(419) 592-4010 Phone
(419) 599-8393 Fax

**SURVEY OF LOTS 7 AND 10 OF BECK AND SCHULTZ REPLAT OF LOT 7,
BEING A PART OF THE SE 1/4 OF THE SE 1/4 OF SECTION 11, T 5 N, R 6 E,
NAPOLEON TOWNSHIP, CITY OF NAPOLEON, HENRY COUNTY, OHIO.**

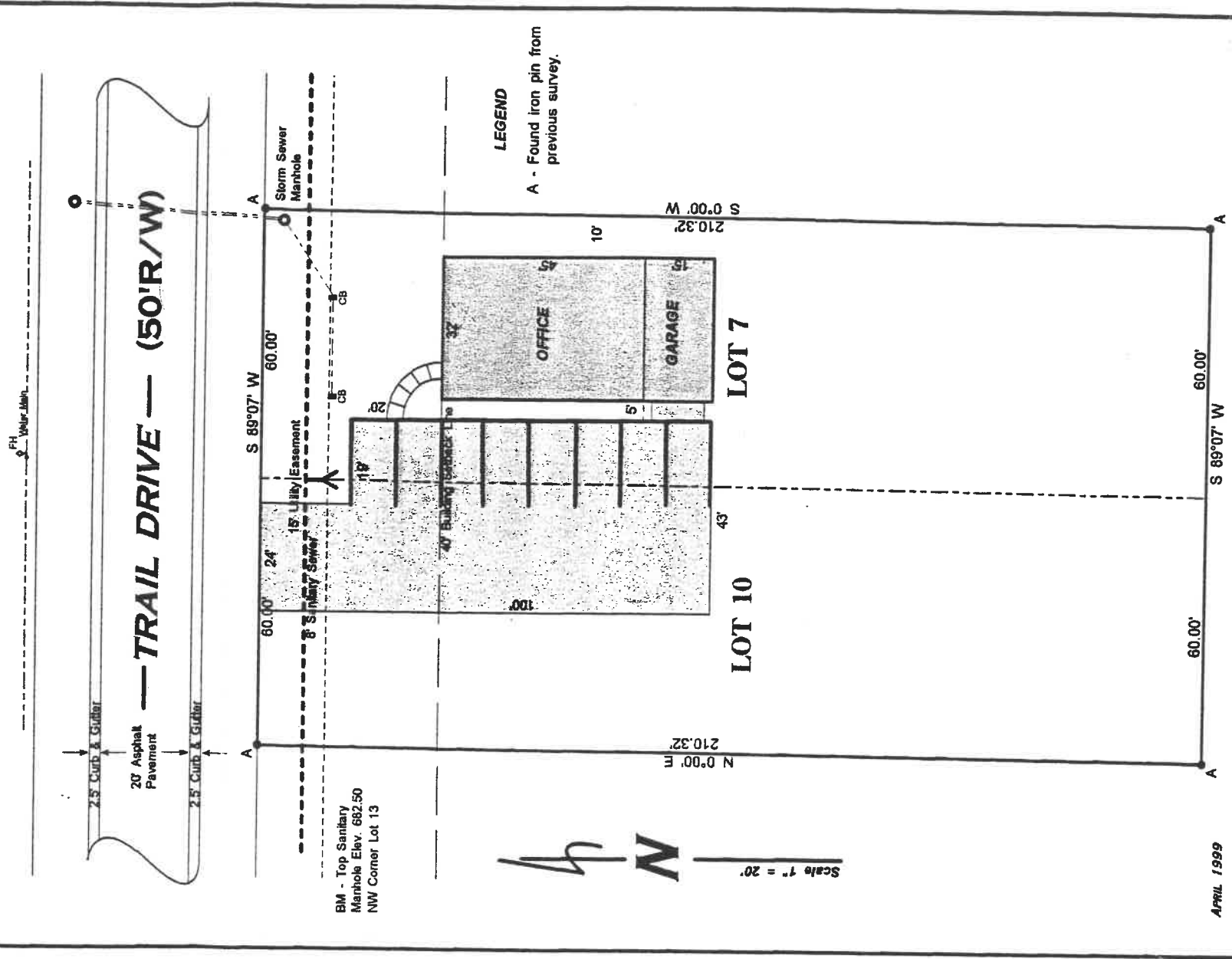

BM - Top Sanitary
Manhole Elev. 662.50
NW Corner Lot 13

Scale 1" = 20'

LEGEND
A - Found iron pin from
previous survey.

APRIL 1999
I HEREBY CERTIFY THIS SURVEY TO BE CORRECT
TO THE BEST OF MY KNOWLEDGE.

HERBERT BEHRMAN, REG. SURVEYOR NO. 5778

HERBERT BEHRMAN
REGISTERED PROFESSIONAL SURVEYOR
No. 5778
NAPOLEON, OHIO 43054
7524 Road D, New 41926648
TRAIL DRIVE

**SURVEY OF LOTS 7 AND 10 OF BECK AND SCHULTZ REPLAT OF LOT 7,
BEING A PART OF THE SE 1/4 OF THE SE 1/4 OF SECTION 11, T 5 N, R 6 E,
NAPOLEON TOWNSHIP, CITY OF NAPOLEON, HENRY COUNTY, OHIO.**

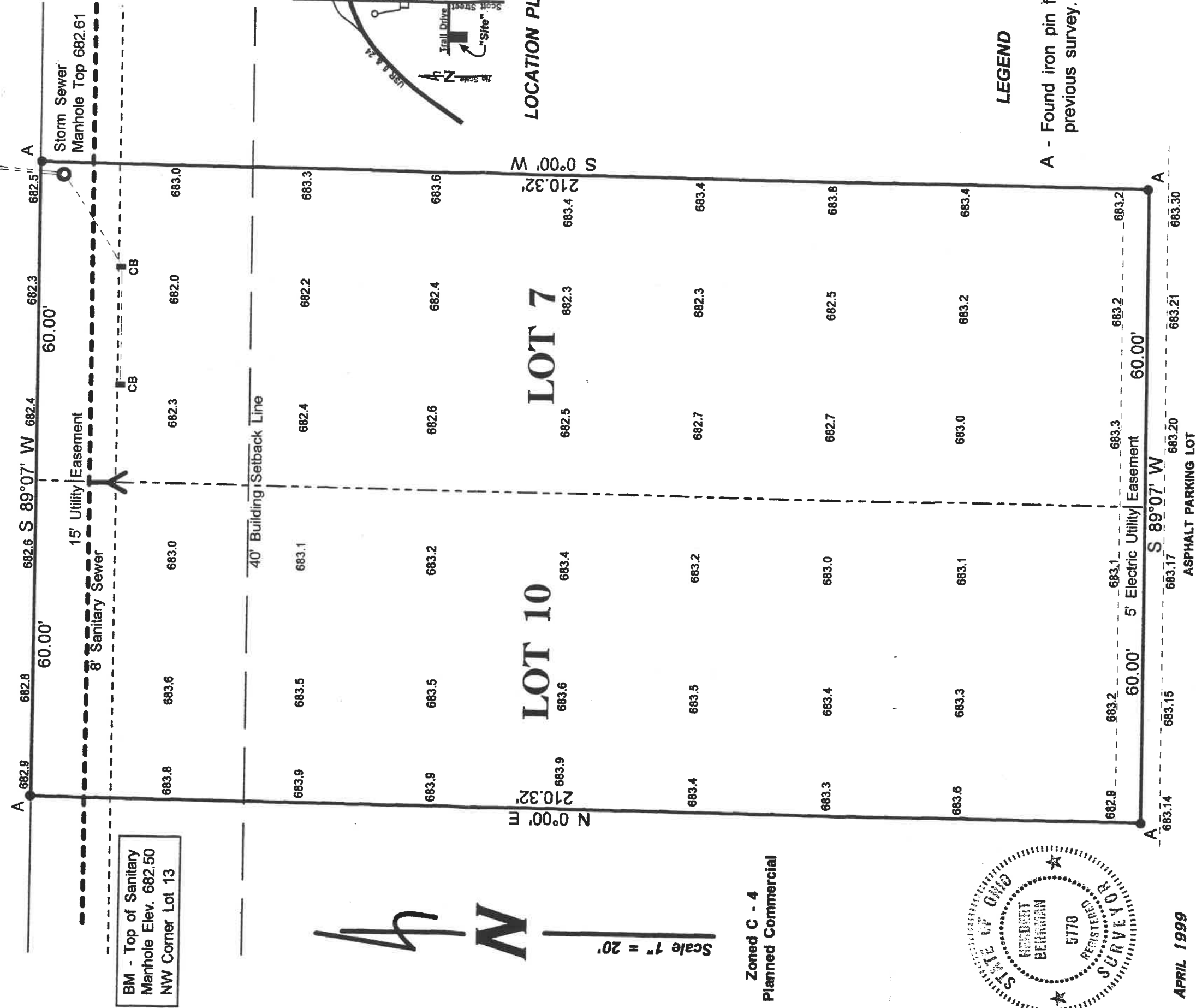
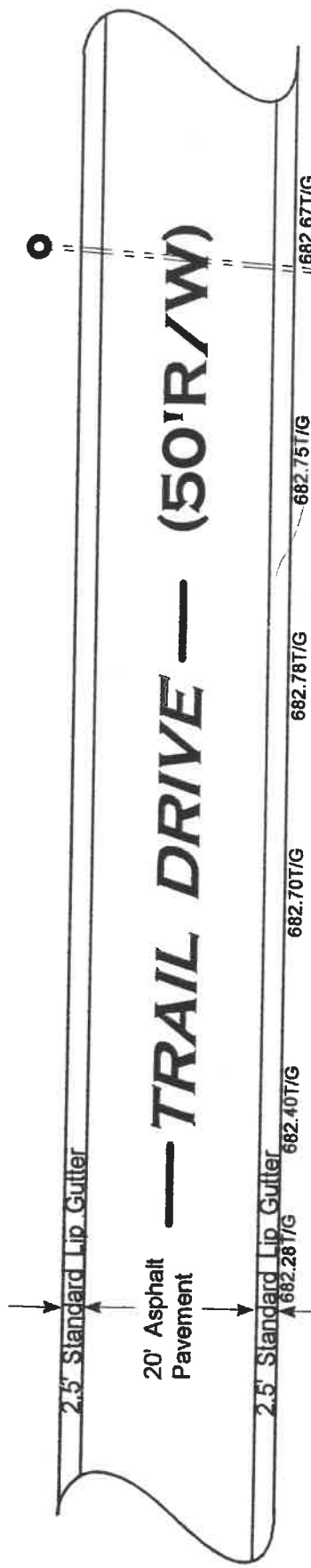

BM - Top of Sanitary Manhole Elev. 682.50 NW Corner Lot 13



Zoned C - 4
Planned Commercial

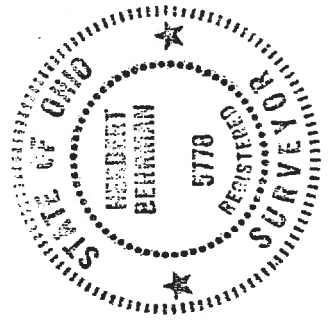

APRIL 1999

I HEREBY CERTIFY THIS SURVEY TO BE CORRECT TO THE BEST OF MY KNOWLEDGE.

Herbert Behrman
HERBERT BEHRMAN, REG. SURVEYOR NO. 5778

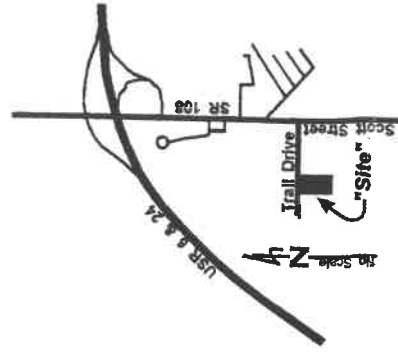

LOCATION PLAN

LEGEND

A - Found iron pin from previous survey.

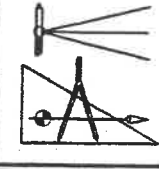

HERBERT BEHRMAN
REGISTERED ENGINEER NO. 34313
REGISTERED SURVEYOR NO. 5778
HAMILER, OHIO 43524
7234 ROAD D PHONE 4192746445
NAPOLEON, OHIO
BOUNDARY & TOPOGRAPHIC SURVEY FOR ROD FARSELL, D28
NAPOLEON, OHIO
TRAIL DRIVE

City of Napoleon

Fax Cover This is a confidential message, intended solely for the person to whom it is addressed. If you receive this message in error, please forward it to the correct person, or mail it back to us. Thank you.

To Dave Casler
Fax No. (419) 335-8889
From Adam C. Hoff, P.E. - City Engineer
Date 5/20/99
Subject Dentist Office Plan Review
Pages 1, including this one

Based upon Staff review of the site plan submitted for the referenced project, on behalf of the City of Napoleon, I hereby approve the site plan for the proposed dentist office for Dr. Rod Parsell to be located on Trail Drive. Please note, if the City is to provide inspection for the proposed site improvements, an inspection fee of 1.5% of the estimated cost for the site improvements, plus contingencies, will be required. Such a fee would also cover the required sanitary sewer inspection fee.

A water tap charge of \$680.00 for the proposed 3/4" meter will be required as well as a \$600.00 tap charge for the sanitary sewer. Should the owner opt not to utilize City personnel for the site inspection, an additional fee for inspection of the sanitary sewer tap in the amount of \$110.00.

If you have any questions, please call me at 592-4010. Thank you.

Adam C. Hoff, P.E. - City Engineer

c: Tony Druhot, Jeff Marhugh, Brent Damman, Rex Moll

255 W. Riverview Ave.
Napoleon, Ohio 43545

(419) 592-4010 Phone

(419) 599-8393 Fax

Fax Cover This is a confidential message, intended solely for the person to whom it is addressed. If you receive this message in error, please forward it to the correct person, or mail it back to us. Thank you.

To Dave Casler

Fax No. (419) 335-8889

From Adam C. Hoff, P.E. - City Engineer *ACH*

Date 5/14/99

Subject Dentist Office Plan Review

Pages 2, including this one

(419) 337-7425

Based upon Staff review of the site plan submitted for the referenced project, we have developed the following comments:

1. The existing water main along Trail Drive and proposed water service need to be shown on the site plan. A water survey form utilized by the City to determine backflow prevention requirements must be completed for our records. A copy of the form follows. ✓
2. A reduced pressure principle backflow preventor (RPZ) shall be provided in lieu of the dual detector check assembly shown on sheet 6 of 7. Also, valves will need to be placed at the upstream and downstream ends of the unit. ✓
3. Please let us know ASAP the requested meter size (5/8", 3/4" or 1"). The tap charge is based upon the size of the meter. ✓
4. Please provide my office with a copy of the proposed pavement cross section for the parking lot. ✓
5. The drive approach needs to be defined as 6" concrete over 6" of ODOT Item 304 stone base. Also, the Type 3 curbing will need to be removed and replaced. A drop curb may be provided. ✓
6. A 4' wide sidewalk will need to be placed across the lot frontage. The sidewalk shall be 4" thick over a 4" base of ODOT Item 411, except within 5' either side of the drive approach where the sidewalk shall be at least 6" thick. ✓
7. The existing sanitary tap should be defined as such and noted that the contractor will be required to field verify its location and depth. ✓
8. All of the storm pipes that are to be abandoned shall be sealed with watertight plugs. ✓
9. The toe of the slope for the detention basin should be at Elev. 682.33 to provide positive drainage to the proposed catch basin. The 6" outlet pipe shall be SDR-35. Also, the slopes for the detention area should be no greater than 3:1 to allow for easier mowing. ✓

255 W. Riverview Ave.
Napoleon, Ohio 43545

(419) 592-4010 Phone
(419) 599-8393 Fax

If you have any questions, please call me at 592-4010. Thank you.

c: Tony Druhot, Jeff Marihugh, Brent Damman

CITY OF NAPOLEON CROSS-CONNECTION CONTROL QUESTIONNAIRE

Premise Address _____ Lot # _____ Community _____ Cu. Ft. Content _____ Account # _____
 Branch Size: Domestic _____ Fire _____ Main Size _____ Meter Size _____ Fire _____ Type _____ Meter # _____ Branch Location _____
 Owner: _____ Phone _____ Billing Address _____ Designer _____ Zip Code _____
 Applicant: _____ Phone _____
 Type Service: Residential _____ Residential & Commercial _____ Commercial _____ Fire _____ Dual Fire & Domestic _____ Combined Fire & Domestic _____
 Any Other Water Source: Yes _____ No _____ If Yes, What: Well _____ Cistern _____ Other, Describe _____

DOMESTIC

Type of Premise _____ Water Requirements: Domestic G.P.M. _____
 Single _____ Multiple _____ No. Family Units _____ No. Stories _____ Sprinkler Heads Supplied From Domestic: Yes _____ No _____
 Water Used For Processing _____ Product _____ Cooling _____ Sanitary _____ Culinary/Drinking _____ Other, Explain _____
 Type Of Heating: Forced Air _____ Electric _____ Solar _____ Heat Pump _____ Boiler _____ If Boiler, Steam _____ Hot Water _____ Chemical Treatment: Yes _____ No _____
 Type Of Cooling: Cooling Tower Yes _____ No _____ If Yes, Is There An Air-Gap At Supply: Yes _____ No _____ Chiller: Yes _____ No _____ Chemical Treatment: Yes _____ No _____
 Lawn Sprinkling System: Yes _____ No _____ Self-Draining Hydrants, Fountains, Hose Boxes: Yes _____ No _____ Baptistery: Yes _____ No _____ Method Of Fill _____
 Swimming Pool: Yes _____ No _____ Filled By Hose _____ Piped Connection _____ If Piped Is There An Air-Gap At: Pool _____ Filter _____ Other _____
 Dishwasher: Yes _____ No _____ If Yes: Residential _____ Commercial _____ Soap Educators: Yes _____ No _____ Garbage Disposal: _____ With Piped Connections: Yes _____ No _____
 Whirlpool Or Jacuzzi Bath: Yes _____ No _____ If Yes, Filled By: Piped Connection _____ Deck Faucet _____ Vacuum Breaker At Highest Point: Yes _____ No _____
 Pump Used For Cold Water _____ Capacity G.P.M. _____ Hot Water _____ Capacity G.P.M. _____ Direct Suction From City Service: Yes _____ No _____
 Auxiliary Water Storage: Yes _____ No _____ Type And Capacity In Gallons: Gravity Tank _____ Pressure Tank _____ Reservoir _____
 Auxiliary Water Storage Covered: Yes _____ No _____ Additional Information: _____

FIRE PROTECTION

Type Of System: Dry Sprinkler _____ Wet Sprinkler _____ Dry Riser _____ Wet Riser _____ Hose Cabinets _____ Anti-Freeze Legs: Yes _____ No _____
 Yard Fire Hydrants: Yes _____ No _____ New Hydrants Will Have Drain Holes Tapped And Plugged: Yes _____ No _____
 Pumps Used: Yes _____ No _____ Type And Capacity In G.P.M. Fire _____ Jockey _____ Any Existing Anti-freeze Legs: Yes _____ No _____
 Auxiliary Water Storage: Yes _____ No _____ Type And Capacity In Gallons _____ Auxiliary Water Storage Covered: Yes _____ No _____
 Water Requirements: Fire G.P.M. _____

Water Dist. - White

Customer - Canary

Building Dept. - Pink

Run-off Calculations

A = 0.14 a

C = 0.30 previous

C = 0.90 post

2 years, 24 hr rainfall = 2.60"

RECEIVED

MAY 04 1999

CITY OF NAPOLEON

Q_{2A} = (0.30)(2.60)(0.14) = 0.109 cfs

Q_{2B} = (0.90)(2.60)(0.14) = 0.328 cfs

$\frac{.328 - .109}{.109} = 2.01 \rightarrow 201\%$

→ 25 yr. Critical Storm

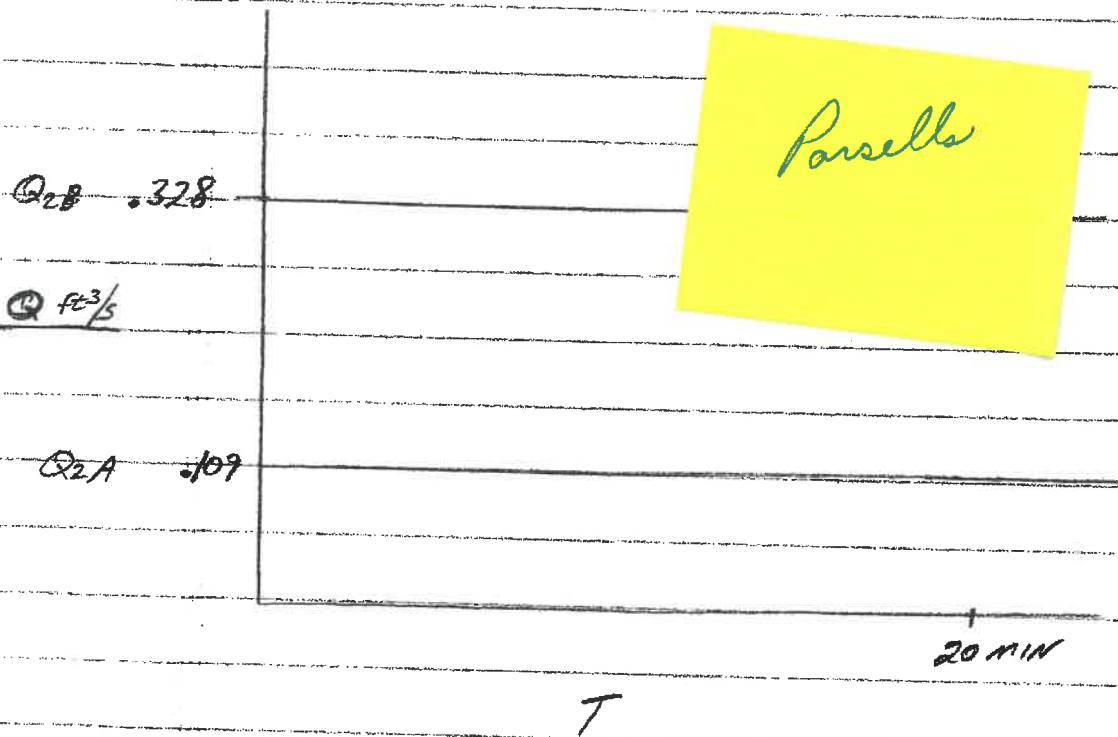

David Cook

Fax Cover This is a confidential message, intended solely for the person to whom it is addressed. If you receive this message in error, please forward it to the correct person, or mail it back to us. Thank you.

To Rod Parsell, DDS
Fax No. (419) 592-7200
From Adam C. Hoff, P.E. - City Engineer *ACH*
Date 4/5/99
Subject Proposed Dentist Office on Trail Drive
Pages 3, including this one

Prior to the City issuing a zoning permit for the construction of your proposed office, several items will need to be addressed. Per the Engineering Rules & Regulations, three (3) copies of a site plan and one (1) copy of runoff calculations shall be submitted for consideration to my office. A plan review of \$25.00 will be required. Following approval of the site plan, an inspection of 1.50% of the estimated cost of construction of the site improvements will also be required (the cost of the building itself is not included in figuring this fee).

Water tap charges vary based upon the size of the service and meter. A standard residential service (1" diameter) with a 5/8" meter is \$650.00, with a 3/4" meter is \$680.00 or with a 1" meter is \$730.00. Services 1-1/2" and larger, regardless of meter size, are charged on a time and materials basis, plus 25%. The actual size of the service required will be determined based upon the fixture units provided with the design of the facility. The tap charge for the sanitary sewer service connection is \$600.00. No additional inspection fee is required for the sanitary service connection.

Mechanical details for the proposed building will also be required to be reviewed by the City. These details shall include the fire suppression system, if required. A reduced pressure principal (RPZ) backflow preventor will be required to be installed just behind the water meter.

There will be no charge for connecting to the City's electric distribution system, unless you opt for an underground service. In that case, you would be charged the incremental difference in cost between an overhead and an underground service.

If you have any questions or require additional information, please call me at (419) 592-4010. Thank you.

c: Jon Bisher, Brent Damman, Jeff Marihugh

255 W. Riverview Ave.
Napoleon, Ohio 43545

(419) 592-4010 Phone
(419) 599-8393 Fax

CITY OF NAPOLEON RULES FOR WATER AND SEWER SERVICE

* Both Capacity and Commodity water charges outside the City are charged at fifty (50%) percent higher than in the City, unless otherwise permitted by Rule. (Amended February 16, 1998 - Ordinance No. 12-98)

Water Tap and Service Line Fees:

The water tap rates charged by the City of Napoleon shall be as follows:

Water Tap and service charges shall be charged as follows:

(A) Water tap and service line fees shall be as follows, unless otherwise permitted by

Rule:

DIA		Tap and Service Line Charge	
Size Tap	Meter Size	Inside City	Outside City
1.00"	5/8"	\$650.00	\$975.00
1.00"	3/4"	680.00	1,020.00
1.00"	1"	730.00	1,095.50

(B) For water tap and service lines of one and one-half (1-1/2") inch or larger in nominal diameter, regardless of the meter size, the fee shall be based on the actual labor and material costs of the tap, lines, meter, meter installation, and other appurtenances and costs associated thereto, plus twenty-five (25%) percent when installed inside the City limits or plus twenty-five (25%) percent when installed outside the City limits; the labor costs will be based on an established hourly rate that will be on file in the City's Utility Department, which may be amended from time to time.

(C) Any water tap made outside the City limits, on City owned lines, shall pay in addition to what has been stated in provision (A) or (B) of this Section, a four thousand (\$4,000.00) dollar fee.

(D) All known fee shall be paid by the applicant in advance of any work or design being performed by the City utility department. All estimated fee amount related to water tap and service charges shall be deposited, in cash, money order, or certified check, with the City Utility Department before any work or design by the City will commence. Any deposit over the actual fee shall be returned to the applicant within sixty (60) days of completion of work; further, any amounts incurred over the deposit amount shall be paid by the applicant to the City within thirty (30) days of being invoiced.

Sanitary Sewer Rates for Inside and Outside Corporation Limits:

The sanitary sewer rates charged by the City of Napoleon shall be as follows:

(A) It is determined and declared to be necessary to the protection of the public health, safety, welfare, and convenience of the City to establish and collect charges upon all lots, lands, and premises which are served by the municipal sanitary sewer system of the City.

CITY OF NAPOLEON RULES FOR WATER AND SEWER SERVICE

Charge/lb of SS above 250 mg/l \$0.15

- BOD = Biological Oxygen Demand
- SS = Suspended Solids

Sanitary Sewer Tap Fees:

(A) A sanitary sewer tap fee (service connection fee) shall be charged for each connection to the City's sanitary sewer system as follows: (This fee does not cover any labor and material required any such labor or materials is a separate charge based on actual cost.)

(B) Charges as contained in this section is applicable and shall be charged for all tributary parcels now in the City to which a sanitary sewer has not been assessed and also for all parcels hereafter annexed to the City. This charge is also applicable and shall be made for all new buildings, major additions, or alterations; to buildings causing increased sewage discharge; any land use causing the discharge of sewage into the sewage system; and any change in sewage flow distribution ordered by the City Manager when the redistribution of sewage flow requires the construction of a new trunk line sewer and a new service connection thereto.

(1) For subdivisions with single-family dwellings, the sanitary sewer tap charge shall be based upon a minimum of \$87.00 per 7,200 square feet of land exclusive of dedicated streets, or a charge of \$87.00 per dwelling unit location, whichever is greater. Anything over the first 7,200 square feet of land shall be on a pro rata basis.

(2) For subdivisions with multifamily units of any nature, or manufactured homes courts, the sanitary sewer tap charge shall be based upon a minimum of \$87.00 per 7,200 square feet of land exclusive of dedicated streets, or a charge of \$87.00 per dwelling unit location whichever is greater. Anything over the first 7,200 square feet of land shall be on a pro rata basis.

(3) For all other developments of any kind, excluding commercial or industrial, the sanitary sewer tap charge shall be based upon a minimum of \$87.00 per 7,200 square feet of land, exclusive of dedicated streets, or a charge of \$87.00 per dwelling unit location, whichever is greater. Anything over the first 7,200 square feet of land shall be on a pro rata basis.

(4) All commercial or industrial uses, the sanitary sewer tap charge shall be six hundred (\$600.00) dollars.

(5) All sanitary sewer tap fees outside the corporation limits shall be increased 50% from what is stated in this provision.

(C) Inspection fees for sanitary sewer taps shall be as follows:

(1) Single-family and duplex residential: \$60.00

(2) Multifamily residential, commercial, and industrial fifty (50') feet in length or less: \$100.00

(3) Multifamily residential, commercial, and industrial fifty-one (51') feet in length or more: \$100.00, plus an additional \$10.00 for each fifty (50') increments over and above the initial fifty (50') feet length.

Detention Calcs for: DCASLER - Dentist Office
 Project No.: 1362-0001

Date: 5-May-99
 Engineer: Worline, Tim R.

GROSS AREA 25,238 SF 0.579 acres
 PAVEMENT AREA 6,213 SF
 STONE AREA 0 SF
 LAWN AREA 19,025 SF

Weighted Runoff Coeff. = 0.4100

Q allow = CIA = 0.25
 I=3.2 "/hr (5 year at 20 min storm)

C	IN/HR	Q					
0.25	3.2	0.4635 cfs					
tc	I25	CwA	Qin	Qout	R	R x tc x 60	Cu. Ft.
20	4.40	0.2376	1.0453	0.4696	0.5757	691	
30	3.60	0.2376	0.8552	0.4696	0.3856	694	
40	3.00	0.2376	0.7127	0.4696	0.2431	583	
50	2.60	0.2376	0.6177	0.4696	0.1481	444	
60	2.30	0.2376	0.5464	0.4696	0.0768	276	
80	1.90	0.2376	0.4514	0.4696	-0.0182	-87	
100	1.60	0.2376	0.3801	0.4696	-0.0895	-537	
120	1.40	0.2376	0.3326	0.4696	-0.1370	-986	
140	1.20	0.2376	0.2851	0.4696	-0.1845	-1,550	
160	1.10	0.2376	0.2613	0.4696	-0.2083	-1,999	
180	1.00	0.2376	0.2376	0.4696	-0.2320	-2,506	

MAX= 694

Hours required to drain 0.4105926

METER LINE CHECK

Length of line 89 ft
 Slope of line 0.60%
 Pipe Size 6 in
 n Value 0.01
 Ke 0.5
 Assumed max Head 0.5 ft
 Hydraulic Radius 0.125 ft
 Velocity 2.392 f/s
 Pipe Area 0.196 sf
 Design Flow 0.470 cfs

PVC 0.5 ft
 $v^2 = 2gH / (1 + Ke + 29 * n^2 * L / R^{4/3})$

REQUIRED FLOW= 0.4635 cfs

RECEIVED

MAY 10 1999

CITY OF NAPOLEON

**SURVEY OF LOTS 7 AND 10 OF BECK AND SCHULTZ REPLAT OF LOT 7,
BEING A PART OF THE SE 1/4 OF SECTION 11, T 5 N, R 6 E,
NAPOLEON TOWNSHIP, CITY OF NAPOLEON, HENRY COUNTY, OHIO.**

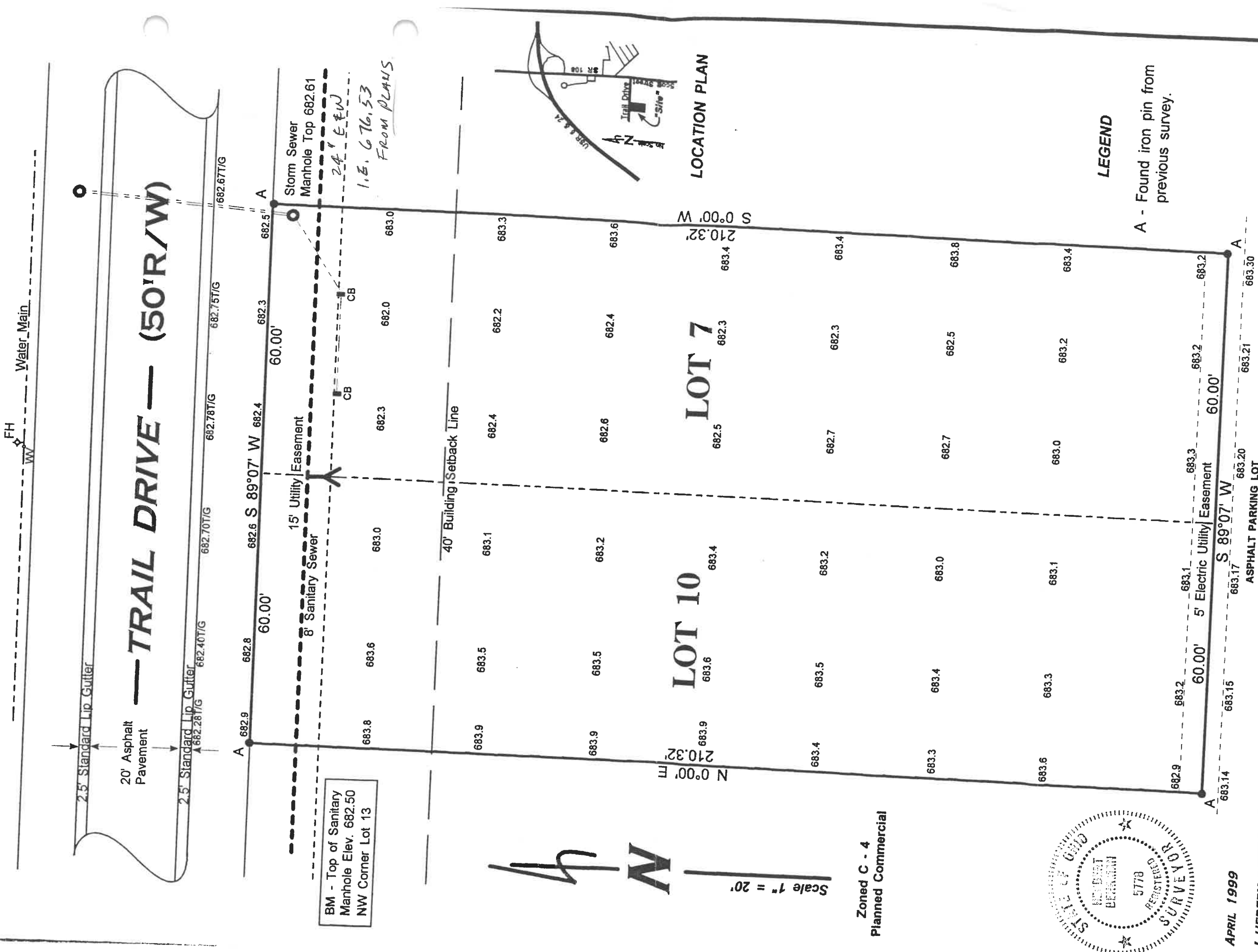

North arrow and scale: Scale 1" = 20'

Zoned C - 4
Planned Commercial

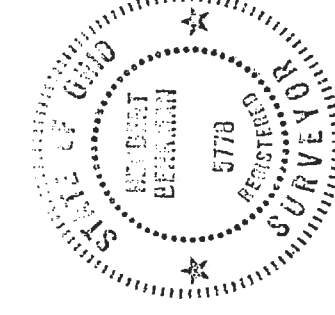

APRIL 1999

I HEREBY CERTIFY THIS SURVEY TO BE CORRECT TO THE BEST OF MY KNOWLEDGE.

Herbert Behrman
HERBERT BEHRMAN, REG. SURVEYOR NO. 5778

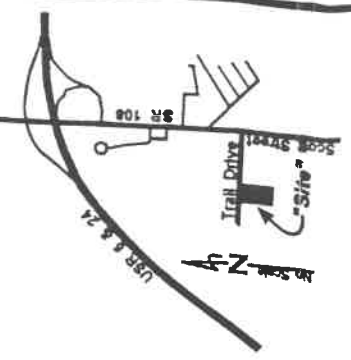

LEGEND

A - Found iron pin from previous survey.

	<p>HERBERT BEHRMAN REGISTERED ENGINEER No. 34313 REGISTERED SURVEYOR No. 5778</p> <p>BOUNDARY & TOPOGRAPHIC SURVEY FOR ROD PARSELL, DDS NAPOLEON, OHIO.</p> <p>7234 ROAD D PHONE 4192746445 TRAIL DRIVE</p>
--	---



210.32'
S 0°00' W

LOT 7,

Iron pin from
previous survey.

60.00'

A

S

APRIL 1999

I HEREBY CERTIFY THIS SURVEY TO BE CORRECT
TO THE BEST OF MY KNOWLEDGE.

HERBERT BEHRMAN, REG. SURVEYOR NO. 5778

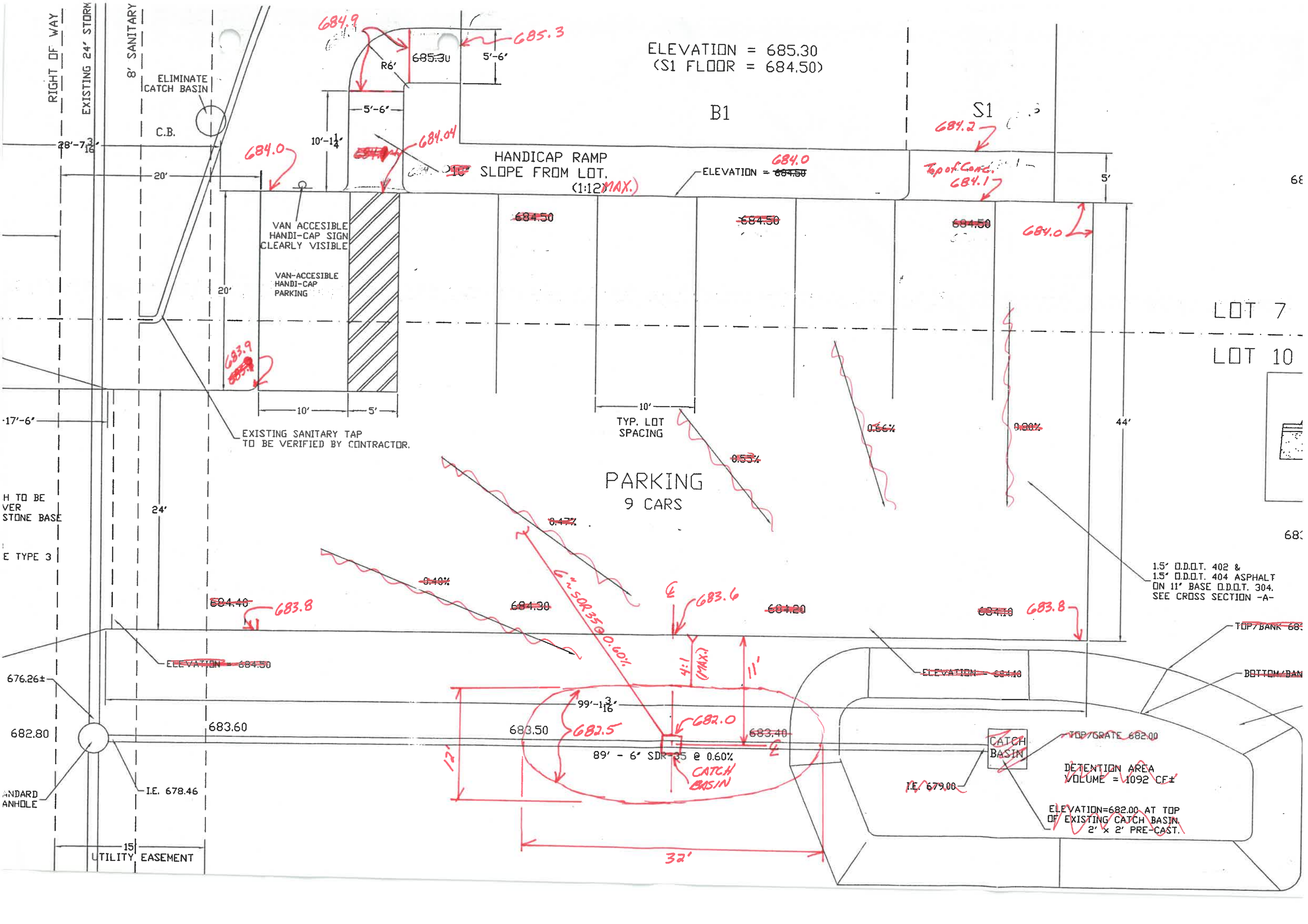

ELEVATION = 685.30
(S1 FLOOR = 684.50)

B1

S1

HANDICAP RAMP
SLOPE FROM LOT.
(1:12 MAX.)

ELEVATION = 684.50

VAN-ACCESSIBLE
HANDI-CAP SIGN
CLEARLY VISIBLE

VAN-ACCESSIBLE
HANDI-CAP
PARKING

PARKING
9 CARS

TYP. LOT
SPACING

EXISTING SANITARY TAP
TO BE VERIFIED BY CONTRACTOR.

1.5' O.D.O.T. 402 &
1.5' O.D.O.T. 404 ASPHALT
ON 11' BASE O.D.O.T. 304.
SEE CROSS SECTION -A-

CATCH
BASIN

DETENTION AREA
VOLUME = 1092 CF±

ELEVATION = 682.00 AT TOP
OF EXISTING CATCH BASIN.
2' x 2' PRE-CAST.

UTILITY EASEMENT

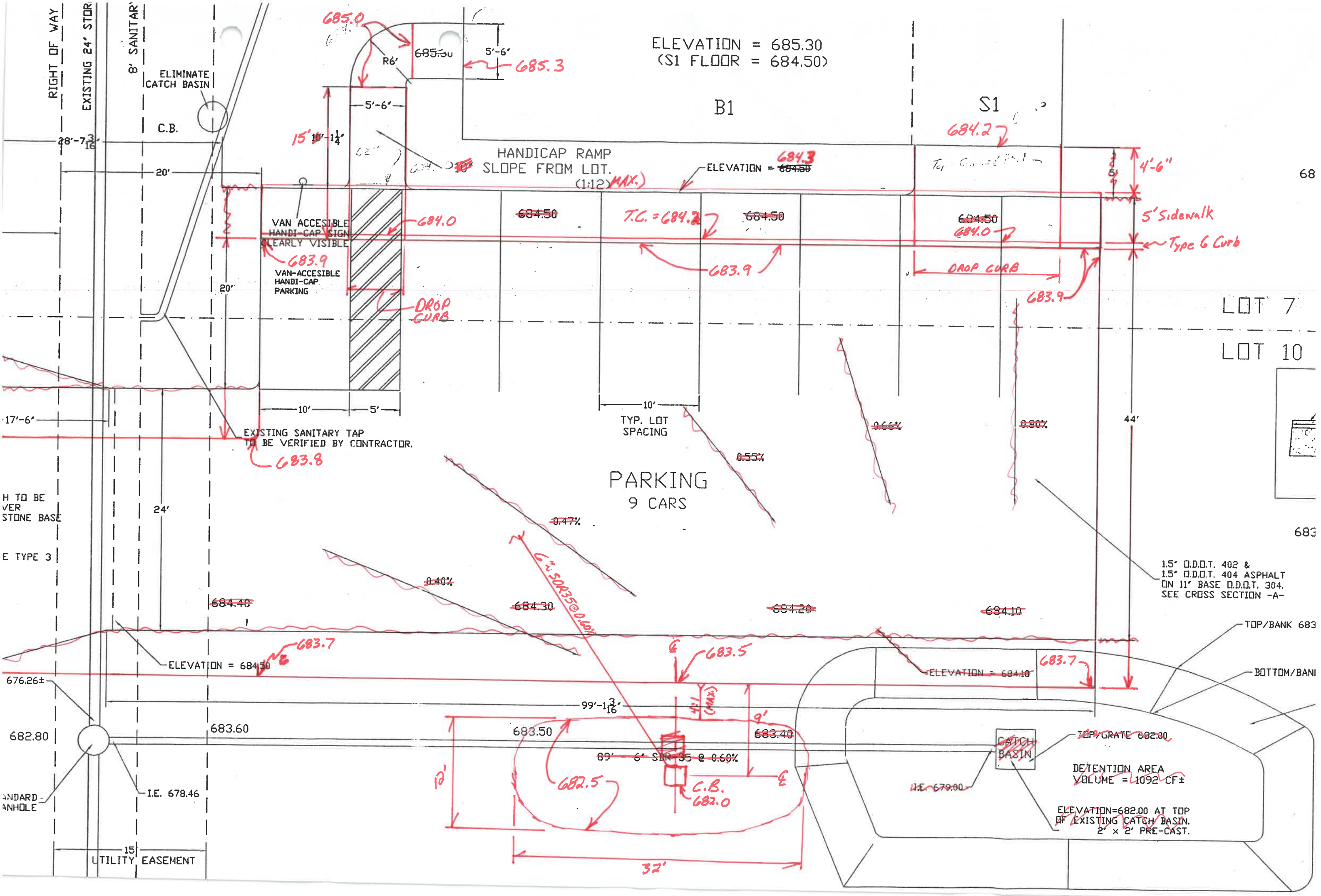

ELEVATION = 685.30
(S1 FLOOR = 684.50)

B1

S1

HANDICAP RAMP
SLOPE FROM LOT.
(1:12) MAX.

ELEVATION = 684.3

VAN ACCESSIBLE
HANDI-CAP SIGN
CLEARLY VISIBLE

VAN-ACCESSIBLE
HANDI-CAP
PARKING

DROP CURB

DROP CURB

5' Sidewalk
Type 6 Curb

PARKING
9 CARS

LOT 7

LOT 10

1.5' O.D.O.T. 402 &
1.5' O.D.O.T. 404 ASPHALT
ON 11' BASE O.D.O.T. 304.
SEE CROSS SECTION -A-

TOP/BANK 683

BOTTOM/BANK 682

CATCH BASIN

DETENTION AREA
VOLUME = 1092 CF±

ELEVATION=682.00 AT TOP
OF EXISTING CATCH BASIN.
2' x 2' PRE-CAST.

ELIMINATE
CATCH BASIN

C.B.

EXISTING SANITARY TAP
TO BE VERIFIED BY CONTRACTOR.

24'

I.E. 678.46

15'
UTILITY EASEMENT

683.60

683.50

683.40

ELEVATION = 684.10

ELEVATION = 684.10

684.40

684.30

684.20

684.10

684.0

684.50

T.C. = 684.2

684.50

684.50

684.0

683.9

683.9

15'-10 1/4'

5'-6'

5'-6'

685.3

685.0

685.30

5'-6'

684.0

684.0

683.9

683.9

683.8

683.7

683.60

682.5

682.0

682.0

32'

89'-6" x 35" @ 0.60%

99'-1 3/16'

683.50

683.40

TOP GRATE 682.00

RIGHT OF WAY

EXISTING 24' SANITARY

8' SANITARY

28'-7 3/16'

20'

20'

20'

10'

5'

10'

TYP. LOT SPACING

0.55%

0.66%

0.80%

44'

H TO BE
VER
STONE BASE

E TYPE 3

676.26±

682.80

STANDARD
MANHOLE

68

683

683

683

683

683

683

683

683